



## **Operating Instructions**

### **Safety Filters**

**SFC-K 40**

**SFC-K 50**

---

**Sterling Material Processing**  
5200 West Clinton Ave.

Milwaukee, WI 53223

Telephone: (414) 354-0970  
Fax: (414) 354-6421

www.sterlco.com

**Parts & Service:**

Telephone: **(800) 423-3183**

**Edition: 06/99**

These operating instructions are for\*:

(\*Please fill in personally)

Serial number: \_\_\_\_\_

Built in: \_\_\_\_\_

Date of delivery: \_\_\_\_\_

Number of delivery: \_\_\_\_\_

Date of commissioning: \_\_\_\_\_

Location: \_\_\_\_\_

Group of machines: \_\_\_\_\_

Sterling Material Processing retains all rights to change the information in these operating instructions at any time without notice.

We assume no liability for any errors or direct or indirect damage resulting in context with these operating instructions.

Copying, translation or publication in any form except for personal use of purchaser requires approval from Sterling Material Processing.

All rights reserved.

## Please note that our address and phone information has changed. Please reference this page for updated contact information.



These manuals are obsolete and are provided only for their technical information, data and capacities. Portions of these manuals detailing procedures or precautions in the operation, inspection, maintenance and repair of the products may be inadequate, inaccurate, and/or incomplete and shouldn't be relied upon. Please contact the ACS Group for more current information about these manuals and their warnings and precautions.

### Parts and Service Department

The ACS Customer Service Group will provide your company with genuine OEM quality parts manufactured to engineering design specifications, which will maximize your equipment's performance and efficiency. To assist in expediting your phone or fax order, please have the model and serial number of your unit when you contact us. A customer replacement parts list is included in this manual for your convenience. ACS welcomes inquiries on all your parts needs and is dedicated to providing excellent customer service.

#### For immediate assistance, please contact:

- North, Central and South America, 8am – 5pm CST +1 (800) 483-3919 for drying, conveying, heating and cooling and automation. For size reduction: +1 (800) 229-2919.  
North America, emergencies after 5pm CST (847) 439-5855  
**North America email: [acsuscanadacustserv@corpemail.com](mailto:acsuscanadacustserv@corpemail.com)**
- Mexico, Central & South America  
**Email: [acslatinamericacustserv@corpemail.com](mailto:acslatinamericacustserv@corpemail.com)**
- Europe, Middle East & Africa +48 22 390 9720  
**Email: [acseuropecustserv@corpemail.com](mailto:acseuropecustserv@corpemail.com)**
- India +91 21 35329112  
**Email: [acsindiacustserv@corpemail.com](mailto:acsindiacustserv@corpemail.com)**
- Asia/Australia +86 512 8717 1919  
**Email: [acsasiacustserv@corpemail.com](mailto:acsasiacustserv@corpemail.com)**

### Sales and Contracting Department

Our products are sold by a worldwide network of independent sales representatives. Contact our Sales Department for the name of the sales representative nearest you.

Let us install your system. The Contract Department offers any or all of these services: project planning; system packages including drawings; equipment, labor, and construction materials; and union or non-union installations.

#### For assistance with your sales or system contracting needs please Call:

North, Central and South America +1 (262) 641-8600 or +1 (847) 273-7700 Monday–Friday, 8am–5pm CST

Europe/Middle East/Africa +48 22 390 9720

India +91 21 35329112

Asia/Australia +86 512 8717 1919

#### Facilities:

ACS offers facilities around the world to service you no matter where you are located. For more information, please visit us at [www.acscorporate.com](http://www.acscorporate.com)

United States:

#### ACS Schaumburg – Corporate Offices

1100 E. Woodfield Road  
Suite 588  
Schaumburg, IL 60173  
Phone: + 1 847 273 7700  
Fax: + 1 847 273 7804

#### ACS New Berlin – Manufacturing Facility

2900 S. 160<sup>th</sup> Street  
New Berlin, WI 53151  
Phone : +1 262 641 8600  
Fax: + 1 262 641 8653

Asia/Australia:

#### ACS Suzhou

109 Xingpu Road SIP  
Suzhou, China 215126  
Phone: + 86 8717 1919  
Fax: +86 512 8717 1916

Europe/Middle East/Africa:

#### ACS Warsaw

Ul. Działkowa 115  
02-234 Warszawa  
Phone: + 48 22 390 9720  
Fax: +48 22 390 9724

India

#### ACS India

Gat No. 191/1, Sandbhor Complex  
Mhalunge, Chakan, Tal Khed,  
Dist. Pune 410501, India  
Phone: +91 21 35329112  
Fax: + 91 20 40147576

---

## TABLE OF CONTENTS

<b>1. Safety instructions</b> .....	<b>5</b>
1.1. Warnings and symbols .....	6
1.2. Explanations and information .....	7
<b>2. Installation instructions</b> .....	<b>8</b>
2.1. Transport .....	10
2.2. Installation .....	11
2.3. Compressed air supply .....	12
2.4. Electrical connection .....	13
<b>3. Maintenance</b> .....	<b>15</b>
3.1. Maintenance intervals .....	17
3.2. Cleaning the collecting bin .....	18
3.3. Replacing/cleaning the filter cartridge in the hopper loader .....	19
3.4. Replacing the sealing rings .....	21
3.5. Replacing/cleaning the filter cartridge of the outlet container. . .	23
<b>4. Technical data</b> .....	<b>24</b>
<b>5. Appendix</b> .....	<b>25</b>
5.1. Spare parts list .....	26

## 1. Safety instructions



These safety instructions apply to all persons within the range of action of the equipment.

Please inform all persons within the range of action of the equipment of the direct and indirect hazards connected with the equipment.

These operating instructions are to be used by all persons assigned activities connected with the equipment.

Knowledge of the English language is prerequisite.

Ensure in each case that the operating personnel are familiar with the operating instructions and the function of the equipment.

Observe the safety instructions of the connected conveying system.

## 1.1. Warnings and symbols

The following warnings and symbols are used in these operating instructions:



This symbol indicates danger to life! Fatal or serious injury is possible if the corresponding instructions, regulations or warnings are not observed.



This symbol indicates that serious injury is possible if the corresponding instructions, regulations or warnings are not observed.



This symbol indicates that extensive damage to equipment is possible if the corresponding instructions, regulations or warnings are not observed.



This symbol indicates information important for becoming familiar with the equipment, i.e. technical correlations.



This symbol indicates that a technical term is explained at this point.

## 1.2. Explanations and information

Various terms and designations are used frequently in these operating instructions to ensure clarity. Therefore please note that the terms used in the text stand for the corresponding explanations listed below.

- **Equipment**  
“Equipment” can mean an individual unit, a machine or an installation.
  
- **Operating personnel**  
The “operating personnel” are persons operating the equipment on their own responsibility or according to instructions (minimum age: 16).
  
- **Operator**  
The “operator” of the equipment (production manager, foreman, etc.) is the person responsible for all production sequences. The operator instructs the operating personnel of what is to be done.
  
- **Operating instructions**  
The “plant operating instructions” describe the interaction of the equipment, production sequences or methods. The plant operating instructions must be compiled by the operator of the equipment.
  
- **Equipment foreman**  
When several operating personnel work on one machine, the “equipment foreman” coordinates the sequences. The equipment foreman must be appointed by the operator.
  
- **Trained personnel**  
“Trained personnel” are persons who, due to their training, are authorized to carry out the required work in good practice.



## 2. Installation instructions



These installation instructions are intended for persons with skills in electrical and mechanical areas due to their training, experience and received instructions.

Personnel using these installation instructions must be instructed in the regulations for the prevention of accidents, the operating conditions and safety regulations and their implementation.

Ensure in each case that the personnel are informed.

The installation instructions provided in the corresponding operating instructions apply for all connected equipment.

Observe safety regulations with regard to lifting gear handling

All installation work must be carried out with the equipment disconnected from electrical power and compressed air supply.



For installation work taking place at heights of over approx. 6 feet, use only ladders or similar equipment and working platforms intended for this purpose. At greater heights, the proper equipment for protection against falling must be worn.

Use only suitable lifting gear which is in proper working order and load suspension devices with sufficient carrying capacity. Do not stand or work under suspended loads!

Use suitable workshop equipment.



Install the equipment such that all parts are easily accessible; this facilitates maintenance and repair work.

## 2.1. Transport

The unit is delivered as a complete sub-assembly. Transport the unit on a pallet. Lift the unit only by the wall support flange (B) or by the hopper loader (A). Use only suitable lifting gear (e.g. hoisting crane or forklift).



Observe the carrying capacity of the lifting gear.

Observe the safety instructions for the handling of lifting gear.



Never lift the unit by the valve.

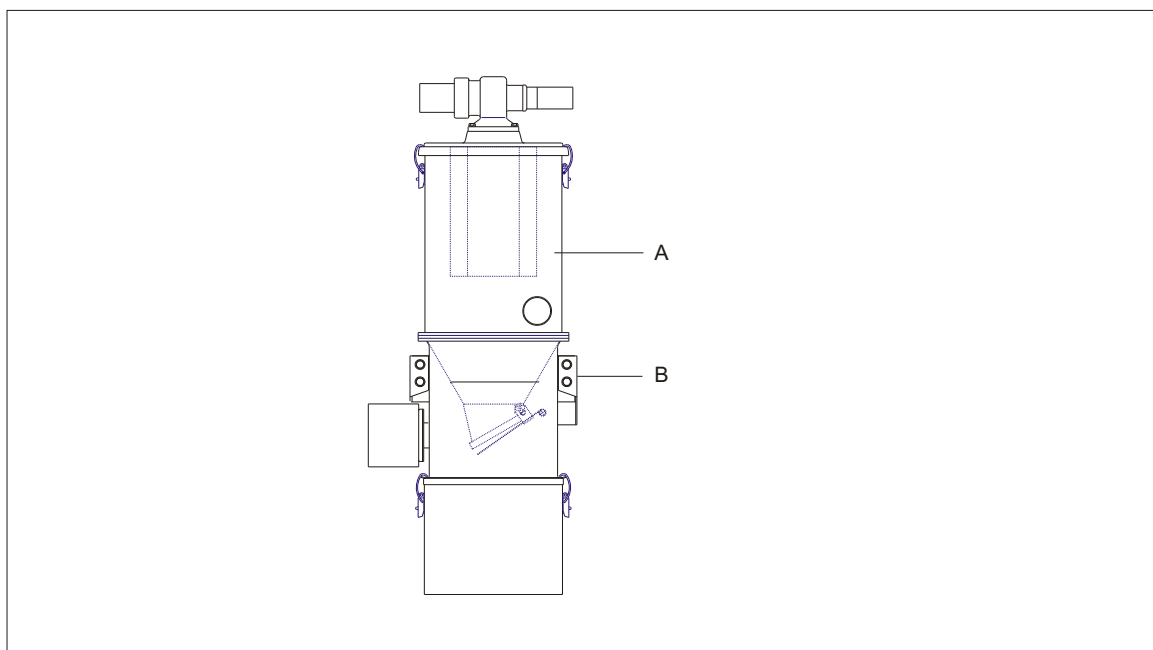

SFC-K

## 2.2. Installation

For installation, the wall support flange (A) is used.



Install the safety filter by means of four screws which guarantee a carrying capacity of at least 50 kg (110.3 lbs.).

Install the safety filter in such a way that all components remain freely accessible for facilitating maintenance and repair work.

Install the safety filter in the suction tube directly before the vacuum generator.

Connect the line to the vacuum generator to the tube of the compressed-air valve (B) by means of a flexible hose. Screw both parts together by means of a hose clamp.

Connect the line to the conveyor units to the tube of the hopper loader (C) by means of a flexible hose. Screw both parts together by means of a hose clamp.

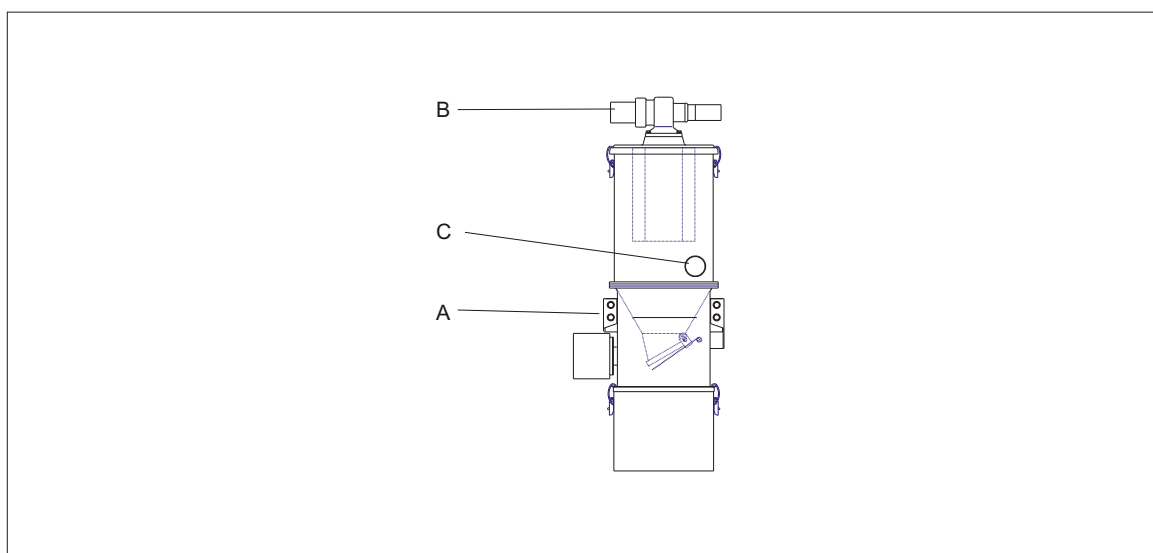

SFC-K

### 2.3. Compressed air supply

For operation of the valve, a compressed-air supply (1/4") is needed.

Check compressed air piping for correct installation and assembly.

Check fittings, length and quality of the hose connections for agreement with requirements.

The operating pressure is 5-6 bar (72 - 87 PSI) (system overpressure).

Check the compressed air supplied by the plant's supply network.

Adjust compressed air pressure to 5-6 bar (72-87 PSI) (system overpressure).

Compressed air must be dewatered and oiled.

Install a maintenance unit (pressure reducer with water separator and oiler) if required.

Connect the unit to the plant's supply network by means of a hose.

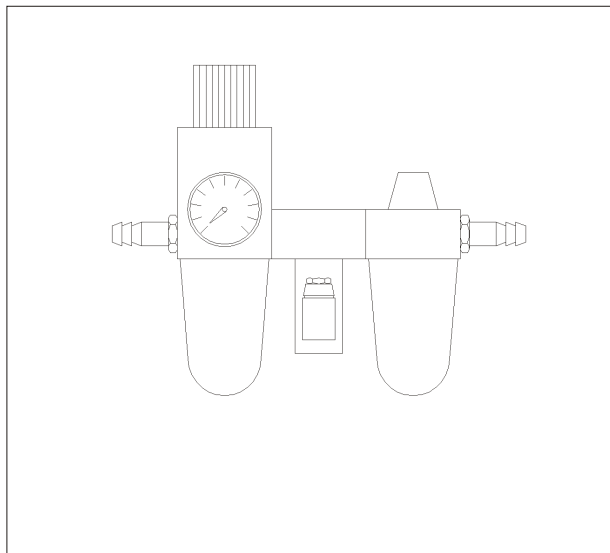

Maintenance unit



Depressurize compressed air supply lines which must be opened.



Compressed air must be dewatered and oiled.

Adjust pressure to a max. value of 6 bar (87 PSI) (system overpressure).

## 2.4. Electrical connection



The electrical connection may only be carried out by trained personnel.

The regulations of the local Electricity Board must be observed.

All work must be carried out with the unit disconnected from voltage and pressure supply.

It is not permitted for other persons to undertake the electrical connection.

Install a cable with three wires ( $3 \times 1 \text{ mm}^2$ ) from the safety filter to the conveying control.

Connect the cable to the plug of the SFC-K's cleaning valve.

Observe the connection diagram:

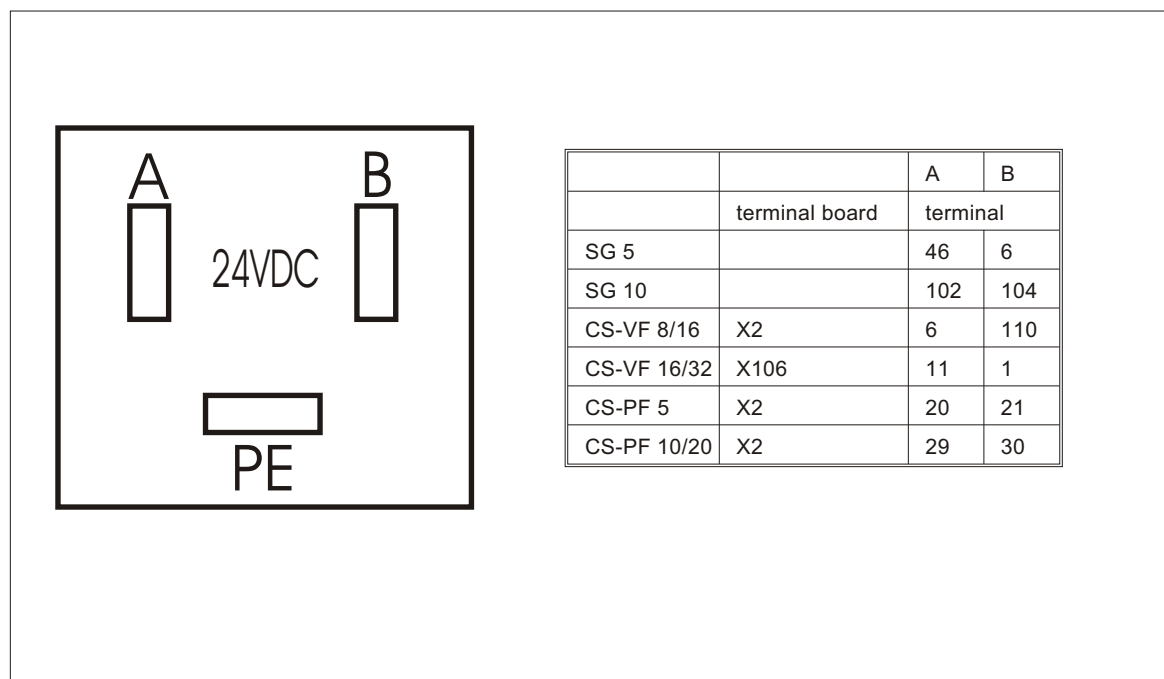

Connection diagram SFC-K



Connect the plug to the cleaning valve of the safety filter and fasten the safety screw.

### 3. Maintenance



This chapter is intended for persons with skills in electrical and mechanical areas due to their training, experience and received instructions.

Personnel using the instructions in this chapter must be instructed of the regulations for the prevention of accidents, the operating conditions and safety regulations and their implementation.

Ensure in each case that the personnel are informed accordingly.

For maintenance work taking place at heights of over approx. 6 feet, use only ladders or similar equipment and working platforms intended for this purpose. At greater heights, the proper equipment for protection against falling must be worn.

Use only suitable lifting gear which is in proper working order and load suspension devices with sufficient carrying capacity. Do not stand or work under suspended loads!

Ensure that the electric motors/switch cabinets are sufficiently protected against moisture.

Use only suitable workshop equipment.

Before starting maintenance work, appoint a supervisor.

Inform the responsible personnel before maintenance work on the system is started.

Never operate the equipment when partially dismantled.

All maintenance and repair work not described in this chapter may only be carried out by Sterling service personnel or authorized personnel (appointed by Sterling).





Disconnect the equipment from mains supply before starting maintenance procedures to ensure that it cannot be switched on unintentionally.

Depressurize all compressed air piping of the equipment before starting maintenance work.



Please observe the maintenance intervals.

Before starting maintenance work, clean the equipment of oil, fuel or lubricants.

Ensure that materials and incidentals required for operation as well as spare parts are disposed of properly and in an environmentally sound manner.

Use only original Sterling spare parts.

Keep record of all maintenance and repair procedures.

### 3.1. Maintenance intervals

Daily:	Check warning signs on equipment for good legibility and completeness. Check the oil level in the oiler. Empty the water separator. Check operating pressure of the plant's supply network (5-6 bar system overpressure). Check waste level in the collecting bin.
Monthly:	Clean the filter cartridges (depending on accumulation of dust earlier!).
Every six months:	Check all electrical and mechanical connections for secure fit. Replace the filter cartridges (depending on accumulation of dust earlier!). Check the sealing rings of the nonreturn valve and the outlet flap.
Yearly:	Replace the sealing rings of the nonreturn valve and the outlet flap.



The service intervals refer to a 3-shift operation.



The given maintenance intervals are average values.

Check whether in your individual case the maintenance intervals must be shortened.

### 3.2. Cleaning the collecting bin



For cleaning of the collecting bin, the plant should be switched off.

Open the toggle-type fasteners (A).

Remove the collecting bin (B) from the support.

Clean the collecting bin (B).

Place the collecting bin (B) back in the support.

Close the toggle-type fasteners (A).

Check the collecting bin (B) for proper fit.

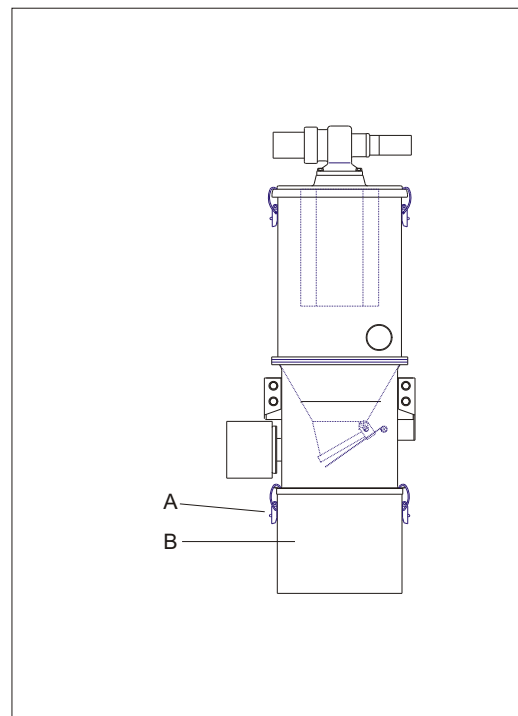

SFC-K

### 3.3. Replacing/cleaning the filter cartridge in the hopper loader



Stop the conveying procedure.

Switch off the conveying system at the main switch.

Interrupt the mains supply.

Set all compressed-air lines at zero pressure.



The conveying capacity is diminished by a clogged filter cartridge.

Open the toggle-type fasteners (A) between the hopper lid and the hopper loader.

Remove the hopper lid with the filter cartridge (B) from the hopper loader.

Remove the locking pin and open the lock nut on the filter cartridge (B).

Remove the filter cartridge (B) from the hopper lid.

Blow compressed air through the clogged filter cartridge from the inside out **or** replace the filter cartridge (B).

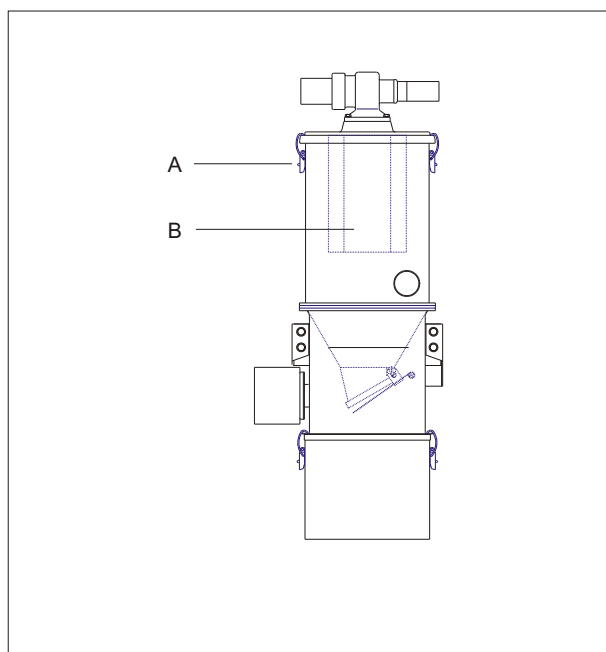

SFC-K

Install the new filter cartridge on the hopper lid.



Use a new lock nut.

Tighten the lock nut with 20 Nm.

Mount the locking pin.

Place the hopper lid with the filter cartridge on the hopper loader.

Close the toggle-type fasteners.



Purchase order number

filter cartridge: ID 85612

lock nut: ID 85486

### 3.4. Replacing the sealing rings



Stop the conveying procedure.

Switch off the conveying system at the main switch.

Interrupt the mains supply.

Set all compressed-air lines at zero pressure.

#### Nonreturn valve

Open the toggle-type fasteners (A) between the hopper lid and the hopper loader.

Remove the hopper lid with the filter cartridge from the hopper loader.

Draw the old sealing ring off the nozzle (B).

Install the new sealing ring.

Place the hopper lid with the filter cartridge on the hopper loader.

Close the toggle-type fasteners (A).

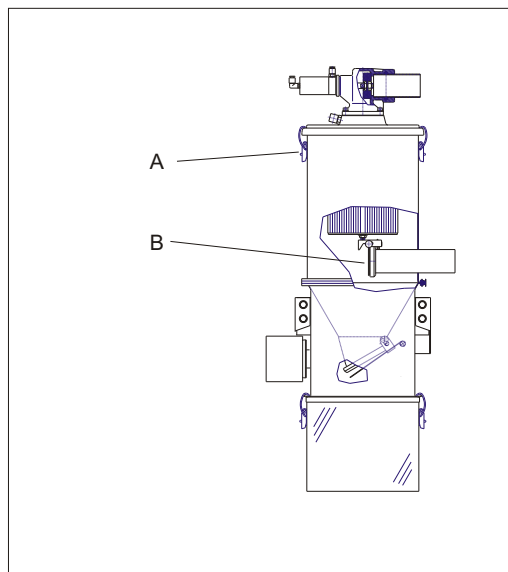

SFC-K



Purchase order number

sealing ring:

ID 85610

## Outlet flap

Open the toggle-type fasteners (A).

Remove the collecting bin (B) from the support.

Remove the old sealing ring (C) from the nozzle of the material outlet.

Install the new sealing ring (D).



Observe the direction of installation (D).

Place the collecting bin (B) back in the support.

Close the toggle-type fasteners (A).



Purchase order number

sealing ring: ID 23098

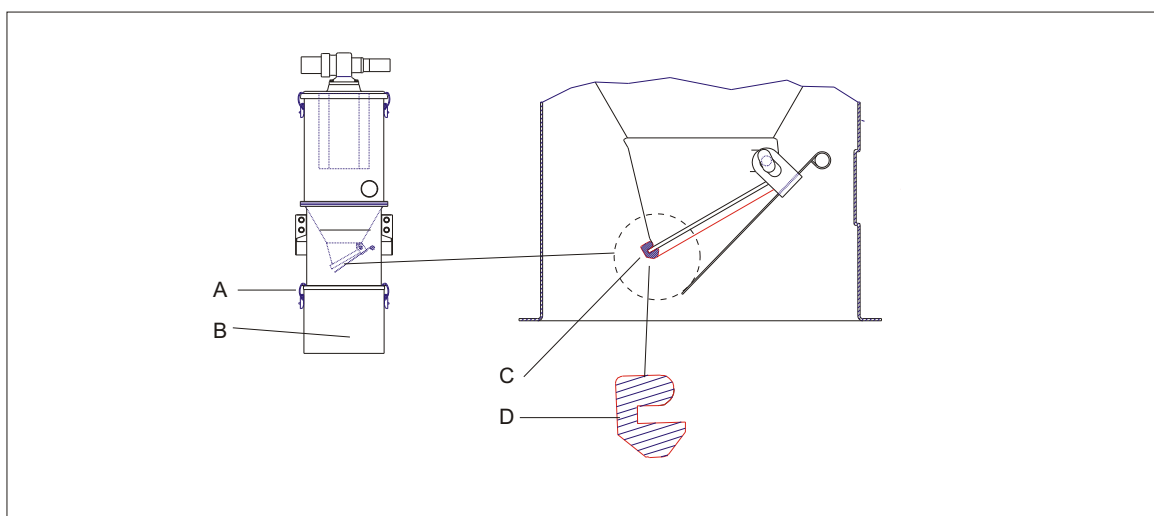

Installation of sealing ring

### 3.5. Replacing/cleaning the filter cartridge of the outlet container



The filter cartridge can also be replaced/cleaned during operation. Because of accumulation of dust, Sterling recommends that you switch off the safety filter.

Slide the filter cartridge off the nozzle of the outlet container.

Blow compressed air through the clogged filter cartridge from the inside out **or** replace the filter cartridge.

Install the cleaned/new filter cartridge.

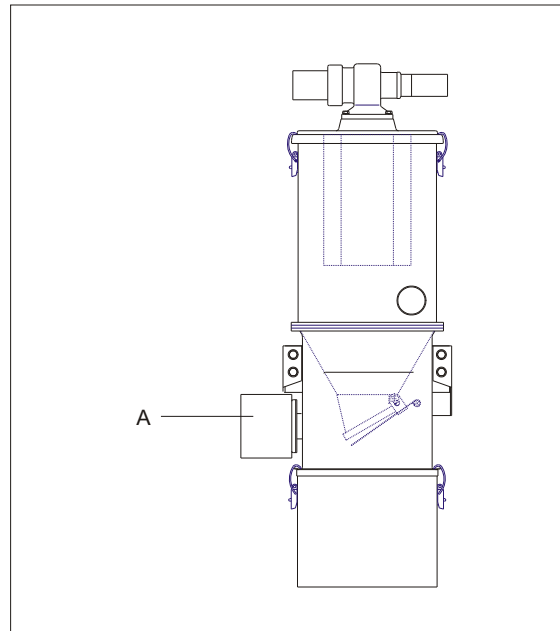

SFC-K



Purchase order number

filter cartridge: ID 98171



#### 4. Technical data

Versions: SFC-K 40  
SFC-K 50

Weight: approx. 10 kg (22 lbs)

Compressed air supply: 4-6 bar (72-87 PSI) system overpressure

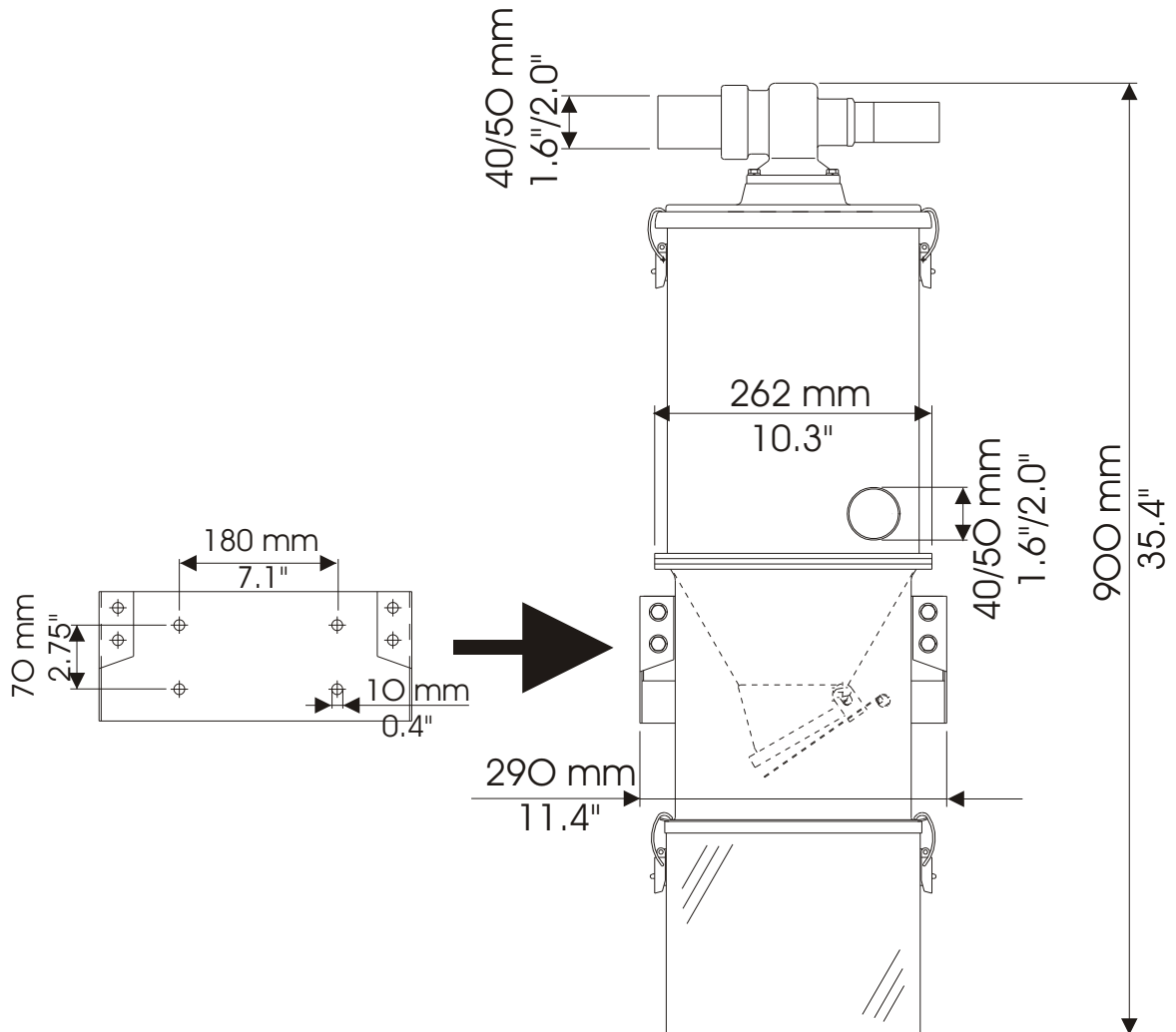

All dimensions are in mm. Subject to alteration.

## 5. Appendix

### 5.1. Spare parts list



This spare parts list is intended to be used only by trained personnel.

Other persons are not permitted to modify or repair the equipment.

SFC-K 40/50

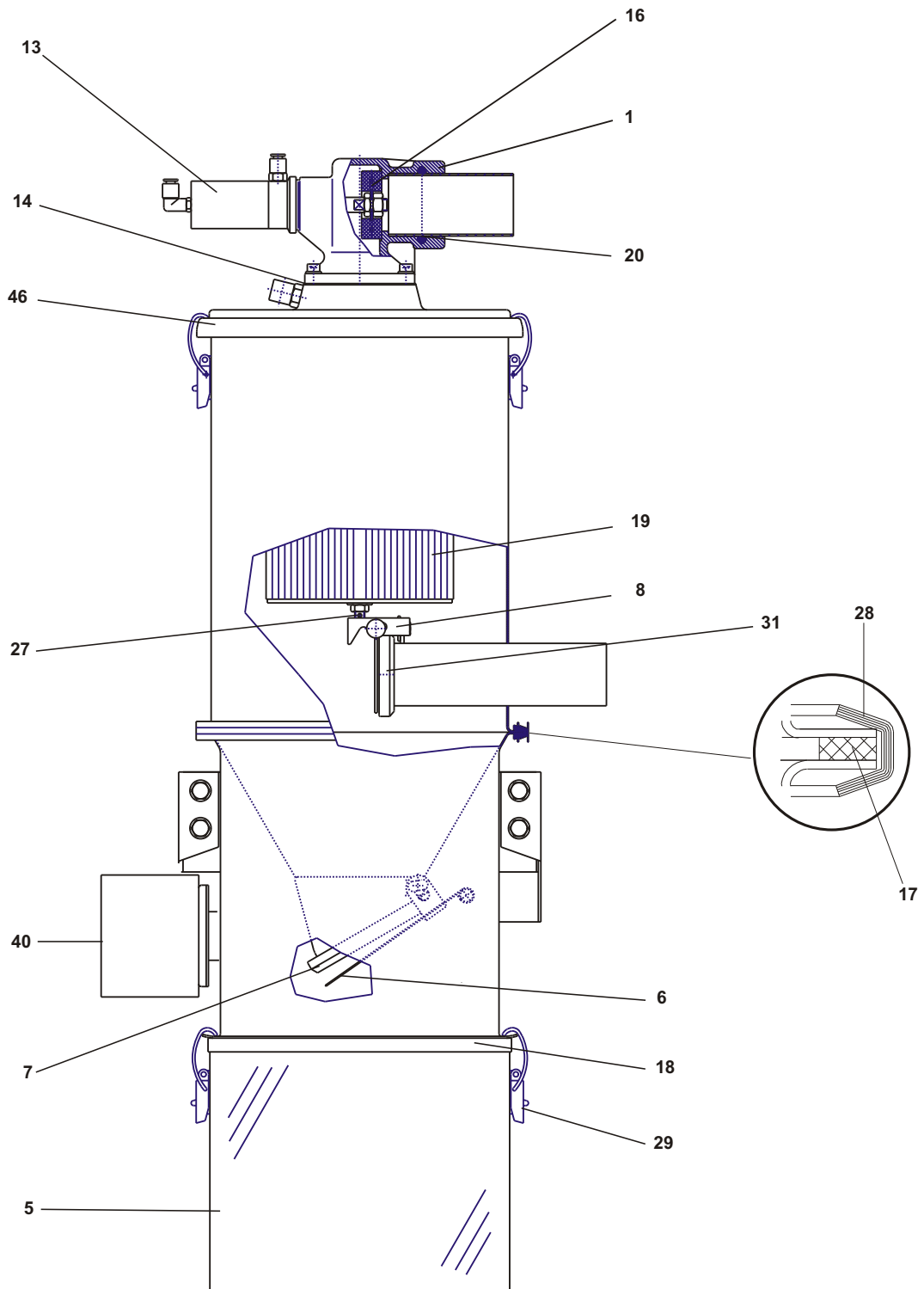

SM3-635b

<b>Pos.</b>	<b>Orderno. / Designation</b>
1	28622 / valve housing
5	28624 / collecting bin
6	23093 / outlet flap with magnet
7	23098 / sealing ring
8	13428 / nonreturn valve
13	28623 / cylinder
14	23092 / sealing
16	09646 / sealing ring
17	28420 / sealing ring
18	28619 / sealing ring
19	85612 / filter cartridge
20	96383 / sealing
27	85486 / lock nut
28	85533 / profile tension ring
29	85497 / toggle-type fastener
31	85610 / sealing ring
40	98171 / filter cartridge
46	29297 / sealing ring